

Bloccafuni  
Rope-clamps  
Treibscheiben Klemmen  
Pinza amarracables  
Serre câbles

PULEGGE SHEAVES TR-SCHEIBEN POLEAS POULIES						
Ø funi Ø ropes Ø Seile Ø câbles Ø cables [mm]	Ø pul. min. Ø sheav. min. Ø Tr.sch min. Ø polea min. Ø poulie min. [mm]	PASSO	PITCH	RILLENABST.		L [mm] 90 KG
		n° gole n° gargantas	n° grooves n° gorges	n° Rillen	n°	
8-9	360	18	18	18	14	26.5
10	400	18	18	18		28.8
11	450	18	18	17		33.2
12	480	18	18	17		34.6
13	520	21	21			37.9
14	560	21	21			40.8
15	600	21	21			42
16	700	21	21			48

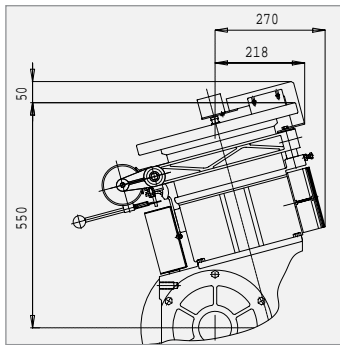

Attacco con encoder  
Coupling for encoder  
Anbau für Impulsgeber  
Embrague encoder  
Accouplement encoder

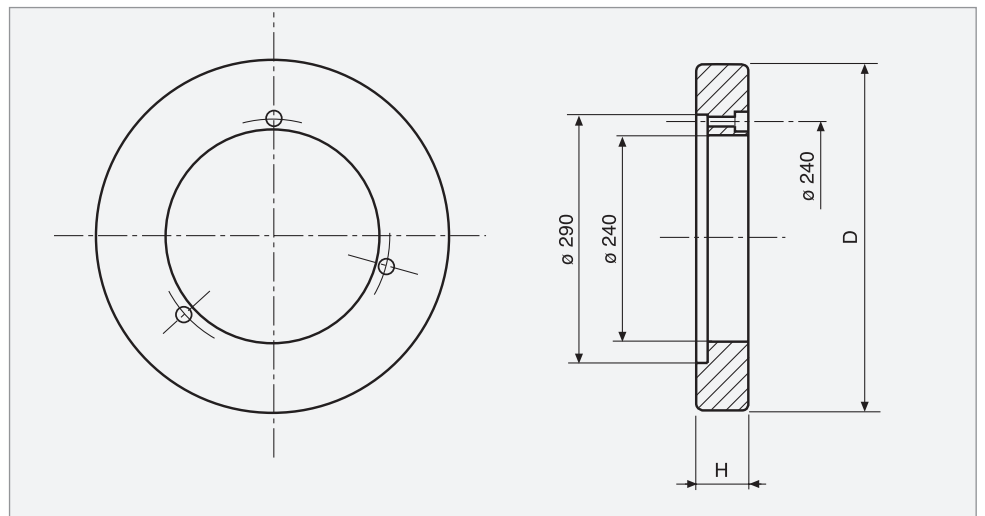

Volano  
Fly-wheel  
Schwungscheiben  
Volante  
Volant

VOLANO TIPO FLY-WHEEL TYPE SCHWUNGSCHLEIBENTYP VOLANTE TIPO VOLANT TYPE	D (mm)	H (mm)	J** (mm)	PESO WEIGHT GEWICHT (kg) PESO POIDS
350 - 24 AMC*	350	24	0.046	2.0
382 - 24 MC	382	24	0.275	8.0

\*In alluminio • In aluminium • Aus Aluminium • En aluminio • En aluminium

$$** J = \frac{GD^2}{4}$$

a	b	Max Static Load kg		Ø	Extended Shaft Code	c	d	e	f	h
		Down/ Sidewards	Upwards							
mm	mm			mm		mm	mm	mm	mm	mm
425	120	2400	2500	70	6002507099	90	22	260	315	95
	130	2000	2100							
	140	1700	1800							
	150	1500	1600							
	160	1300	1400							
500	120	2400	2500	70	6002507098	90	22	260	315	95
	130	2000	2100							
	140	1750	1850							
	150	1500	1600							
	160	1300	1400							
500	140	2300	2400	75	6002507599	90	22	260	320	95
	150	2000	2100							
	160	1750	1850							
	170	1500	1600							
	180	1350	1450							
500	140	2900	3000	80	6002508099	100	22	290	345	100
	150	2500	2600							
	160	2150	2250							
	170	1900	2000							
	180	1650	1750							
600	120	2500	2600	70	6002507097	90	22	260	315	95
	130	2100	2200							
	140	1750	1850							
	150	1500	1600							
	160	1300	1400							
600	140	2300	2400	75	6002507598	90	22	260	320	95
	150	2000	2100							
	160	1750	1850							
	170	1550	1650							
	180	1350	1450							
600	140	2900	3000	80	6002508098	100	22	290	345	100
	150	2550	2650							
	160	2200	2300							
	170	1950	2050							
	180	1700	1800							

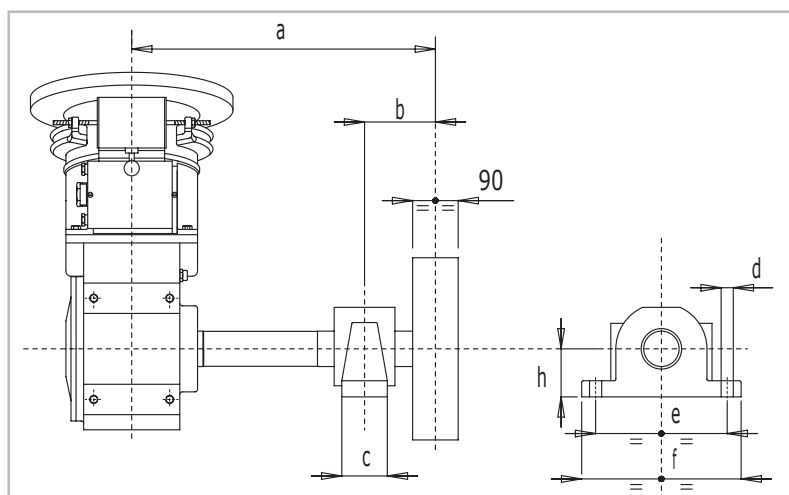

<b>Accessori a richiesta</b>	<b>Accessories on request</b>	<b>Zubehöre auf Anfrage</b>	<b>Accesorios bajo pedido</b>	<b>Accessoires sur demande</b>
Guardafune	Ropesguard	Seilschützbügel	Pinza amaracables	Garde cables
Freno su asse lento	Brake on the slow shaft	Notbremse auf Treibscheibenwelle	Freno de alarma sobre el eje polea	Frein de secours sur l'arbre de la poulie
Manovra di emergenza manuale	Emergency hand operation	Handnotevakuirungsystem	Funcionamiento manuale de emergencia	Manovre manuelle
Manovra di emergenza elettrica	Emergency electrical operation	Elektrisches Notevakuirungsystem	Funcionamiento eléctrico de emergencia	Manovre électrique
Carter di protezione puleggia	Carter for sheave protection	Treibescheibenschütz	Proteccion polea	Protection poulie
Dispositivo Ecobrake	Ecobrake device	Ecobrake Vorrichtung	Sistema ecobrake	Systeme Ecobrake
Alberi allungati	Extended shafts	Verlängerte Welle	Eje largo	Arbres allongés



Telaio piano  
standard

Standard  
flat frame

Standard  
Flachrahmen

Bancada  
standard

Chassis  
plat

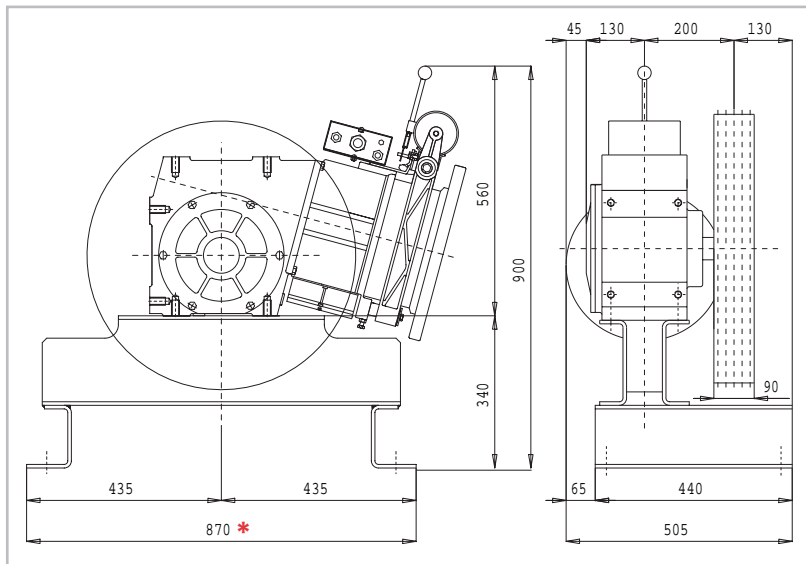

(\*  $\varnothing$  700 = 970 mm)

Telaio alto  
con deviazione

Standard frame  
with divertor

Standard Rahmen  
mit Ablenkung

Bancada  
con desvio

Standard chassis  
avec renvoi

