

SILIKONOVÉ DOSEDACÍ NÁRAZNÍKY PRO KLECE A PROTIVÁHY

Typ	Rozměr průměr DxH(mm)	Zatížení pro danou rychlost (kg)		
		0,4 m/sec.	0,63 m/sec.	1 m/sec.
T1	80x80	153 - 1450	153 - 1300	233 - 500
T2	100x80	153 - 1886	153 - 1137	290 - 800
T3	125x80	153 - 2650	153 - 1344	290 - 1000
T5	220x80	465 - 9200	1000 - 6414	1344 - 6000
E1/T6	100x160	103 - 1344	128 - 1030	128 - 927
E2	125x100	153 - 1661	263 - 1504	263 - 1486
E4/T7	125x100	103 - 1661	153 - 1504	253 - 1442
E5	140x100	203 - 2744	203 - 2120	203 - 1980
E7/T9	165x165	278 - 3434	395 - 3117	465 - 3035
E8	165x220	203 - 4079	303 - 4079	777 - 3919
E9/T10	220x160	465 - 7567	568 - 7043	1344 - 6500
1303	130x220	310 - 5000	310 - 4500	310 - 3322
1411	160x110	310 - 4800	310 - 4500	310 - 3324

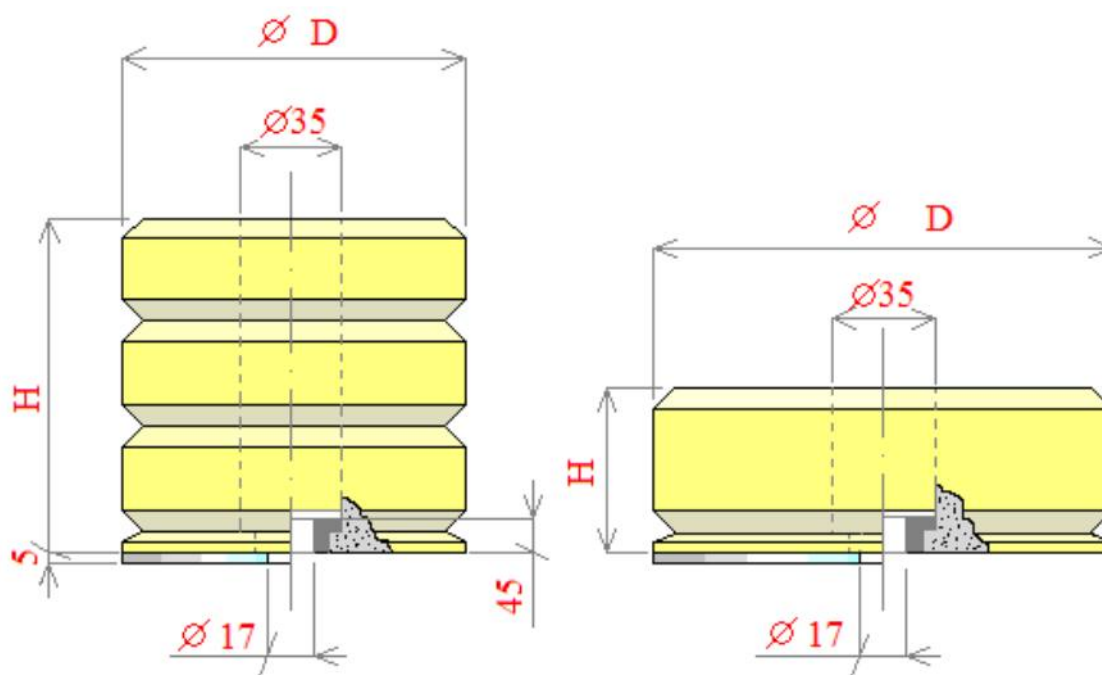

SILIKONOVÉ DOSEDACÍ NÁRAZNÍKY PRO KLECE A PROTIVÁHY

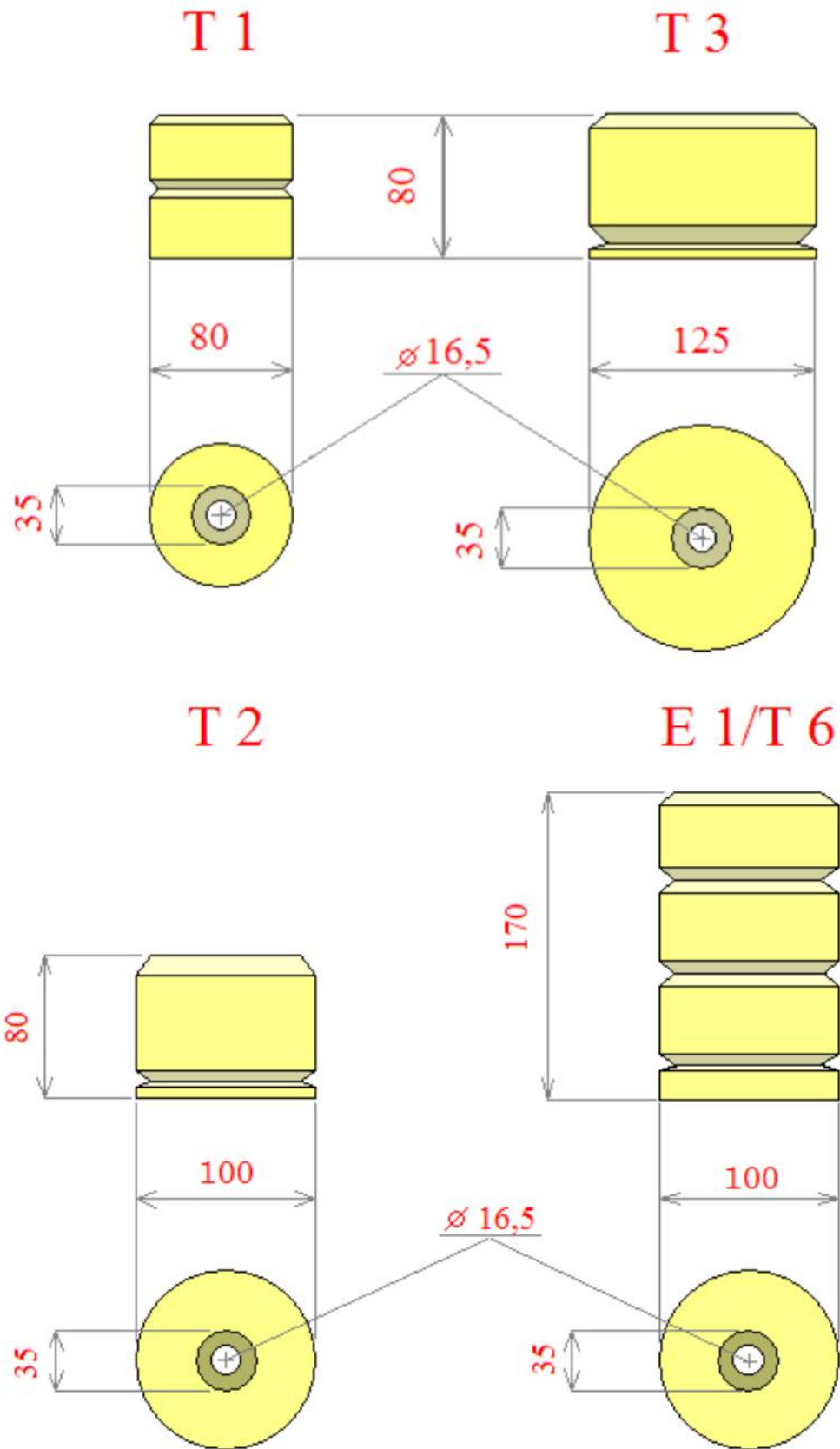

SILIKONOVÉ DOSEDACÍ NÁRAZNÍKY PRO KLECE A PROTIVÁHY

E 7/T 9

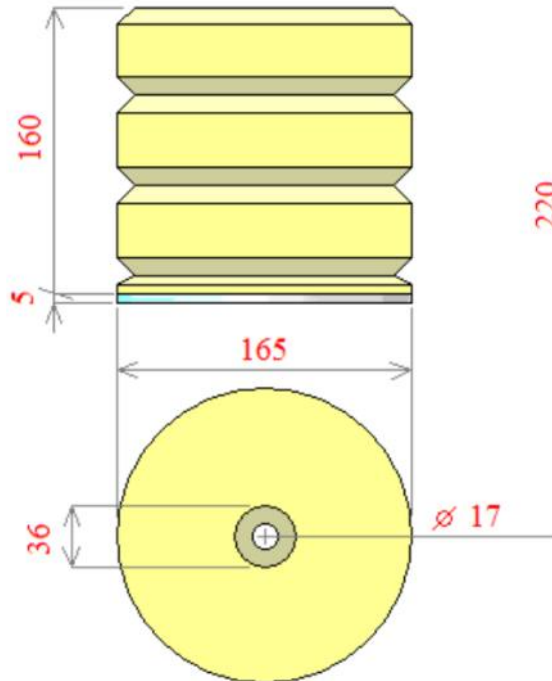

E 8

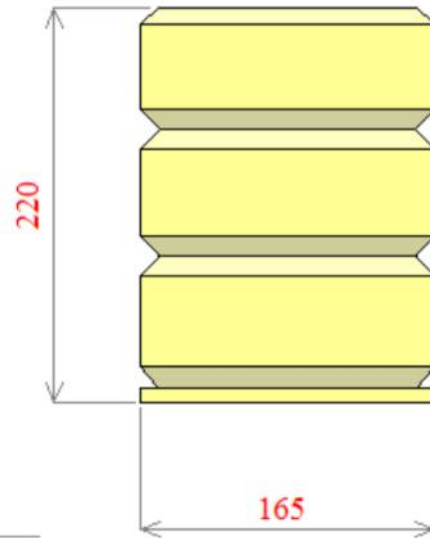

PŮDORYS PRO 1653/E8
JE SHODNÝ S 1652/T9/E7

1303

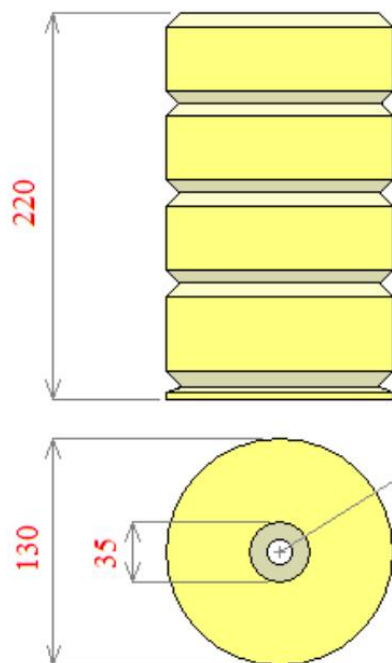

1411

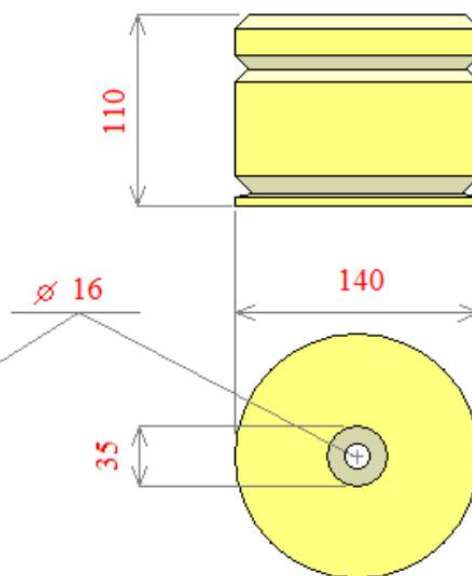

SILIKONOVÉ DOSEDACÍ NÁRAZNÍKY PRO KLECE A PROTIVÁHY

2202/T10/E9

