

SAFETY GEAR **KB 55** ↓

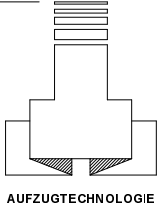

AUFZUGTECHNOLOGIE

**Progressive safety gear - working in DOWN direction only
= rated load + car weight in DOWN direction (FREE FALL)**

**Activated by overspeed governor through overspeed governor rope
(standard finish with tension weight in pit)**

Drawing s shows safety gear block **RIGHT**
hand, **LEFT** hand opposite

IDLE POSITION

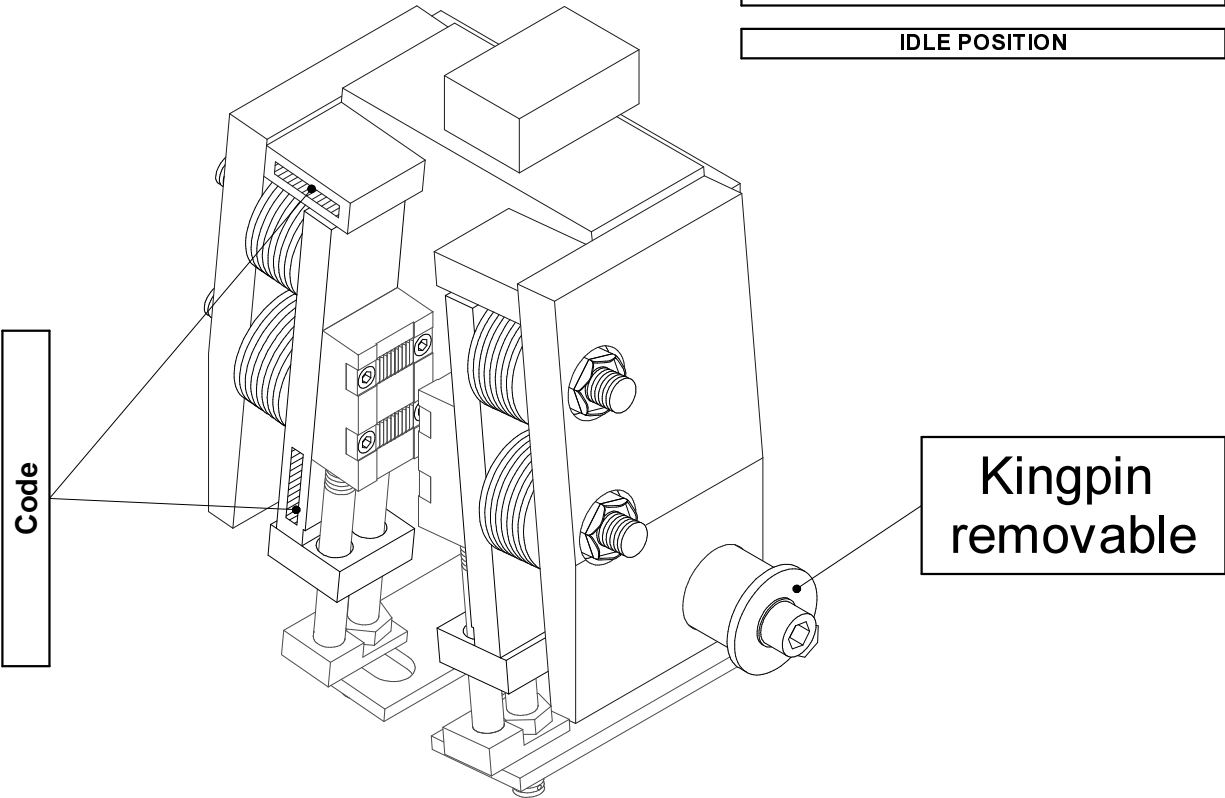

General Information	5260.800.002
Nomination of parts and Outer housing	5260.800.003
Installation and Maintenance	5260.800.004
Adjustment on Site	5260.800.005
Check	5260.800.006
Safety Book - GENERAL - 1	5230.800.016
Safety Book - GENERAL - 2	5230.800.017
Safety Book - CHECKLISTE	5260.800.007
Safety Switch in Idle Position	5230.800.018

SAFETY GEAR

KB 55 ↓

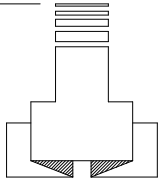

AUFZUGTECHNOLOGIE

Construction - Function:

The knurled tungsten wedge grip on the brake shoe pulls self-locking after engaging and tensions the spring washers

Parameters:
 safety gear type
 guidethickness
 guide rail surface
 total mass
 contract speed
 tripping speed

KB 55
 accord. EC type examination certificate ...
 AFV 333 / _

Guide rail condition: either cold drawn or machined, surface can be either dry or lubricated. Lubricant must be in accordance with DIN 51517, part 1.
 The safety gear type KB 55 is certified to European Standards and hold certificates to DIN EN 81.

Marking:

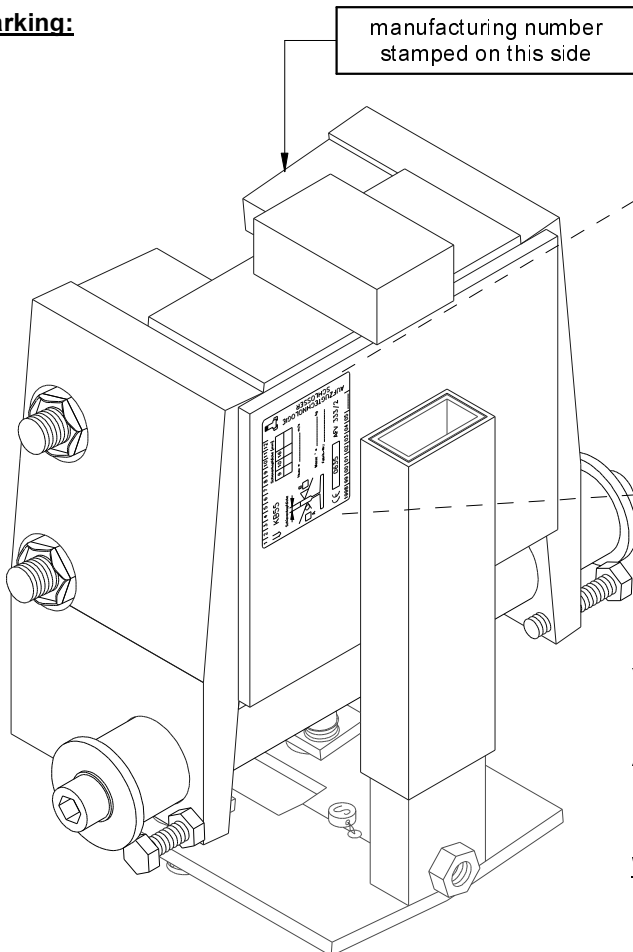

manufacturing number stamped on this side

1	2	3	4	5	6	7	8	9	10	11	12												
↓ KB55			Schienenkopfdicke [mm]																				
			Schienenkopfdicke			V _{Auslöse} = _____ m/s			AUFZUGTECHNOLOGIE SCHLOSSER														
			Masse ↓ = _____ kg			Fabrik-Nr.: _____																	
CE			0635			AFV 333/2																	
1998			99			00			01			02			03			04			05		

type

month of supply

year of supply

manufacturing plant identification

- V_{Auslöse} max. tripping speed
- Masse ↓ total mass in DOWN direction
- A guide rail condition: cold drawn
- B guide rail condition: machined

Warranty and guaranty:

In case our product is not used for the application designed we can not take any responsibility whatsoever. It is the duty of the user to follow the local law and regulations under all circumstances.

SAFETY GEAR

KB 55 ↓

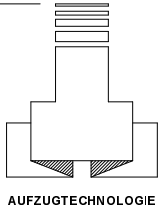

AUFZUGSTECHNOLOGIE

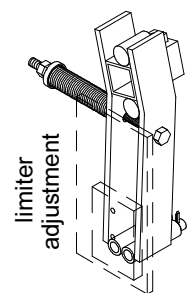
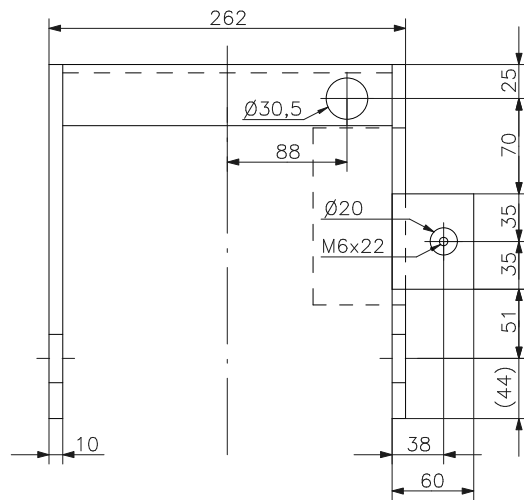
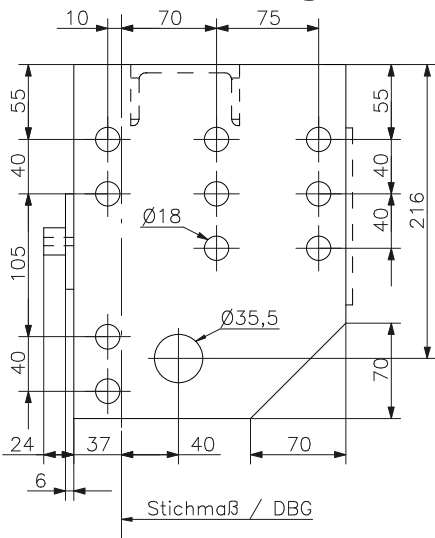
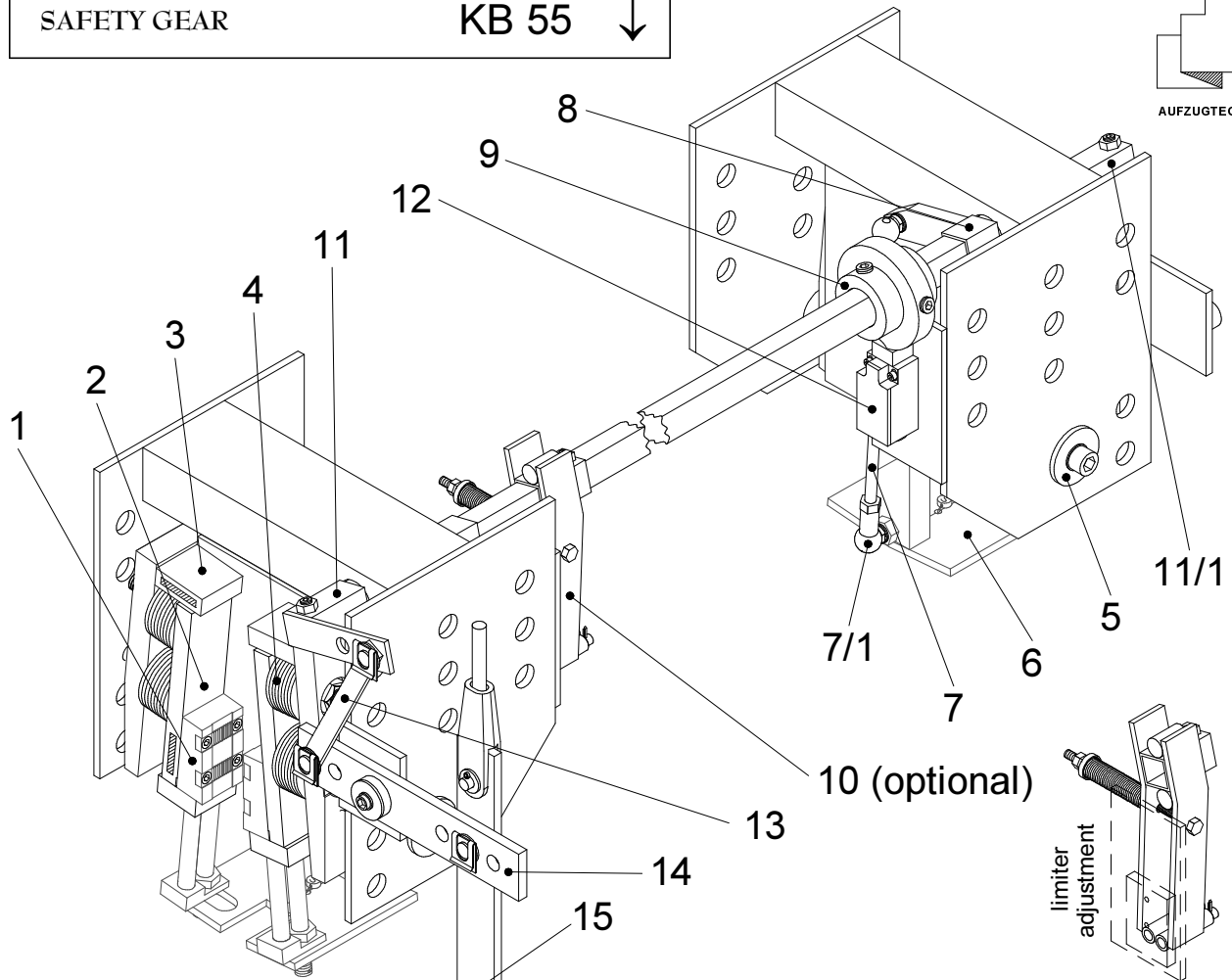

shown RIGHT hand,
LEFT hand opposite

6	2	actuating lever	safety gear KB 55 ↓
5	2	kingpin	
4	12	spring block	
3	2	tension carrier housing	
2	4	sliding wedge	
1	4	brake wedge	
Pos.	Qty.	Nomination of parts	

11	1	actuating lever	connecting rod and switch arrangement
10	1	limiter adjustment opt.	
9	1	trip cam	
8	2	shift lever	
7/1	4	control rod ball joint	
7	2	synchroniser	
Pos.	Qty.	Nomination of parts	

15	1	actuating rope joint	connecting rod and switch arrangement
14	1	operating lever	
13	1	operating shackle	
12	1	safety switch	
11/1	1	shaft guide	
Pos.	Qty.	Nomination of parts	

Edition:
26.07.2001



Manual KB 55 ↓
Partlist + Outer housing standard

Drawing No.:
5260.800.003

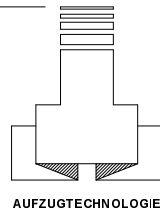

AUFZUGTECHNOLOGIE

SAFETY GEAR

KB 55 ↓

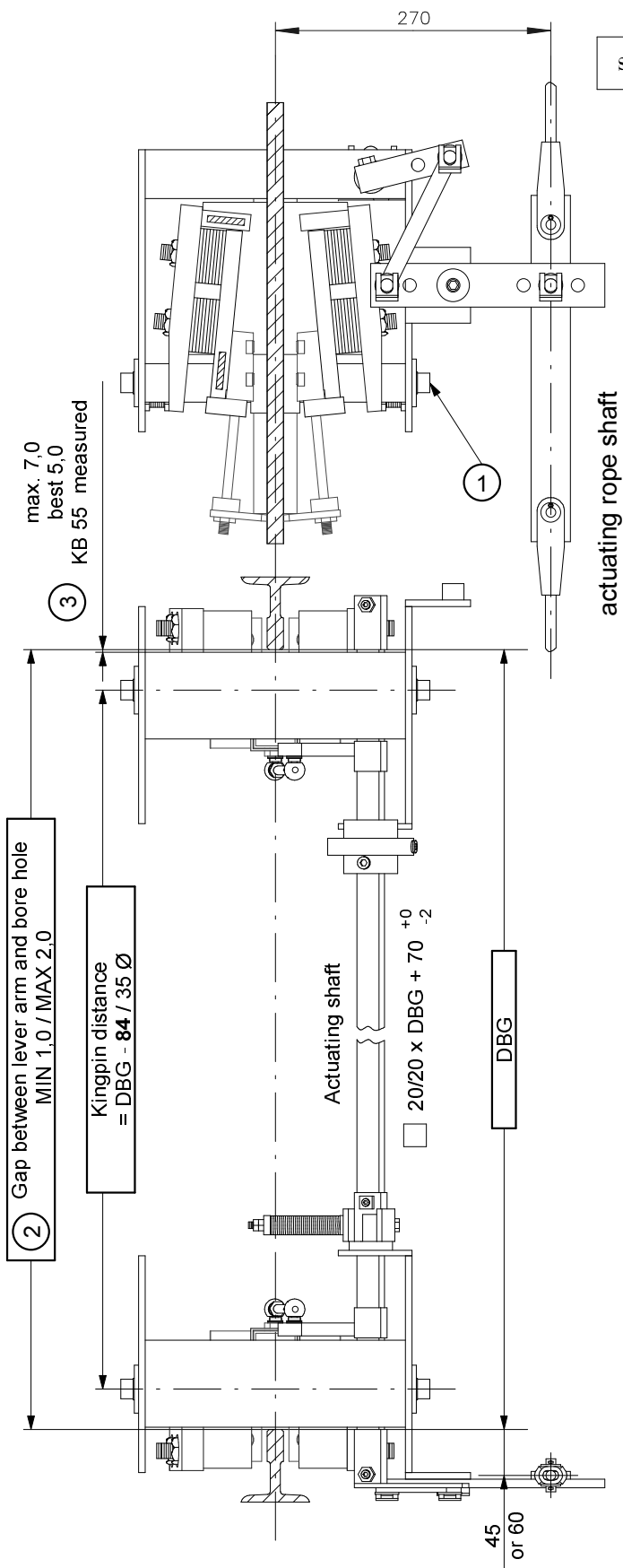

(1) ATTENTION: Safety gears are vital parts of a lift. They are manufactured to DIN ISO 9001 checked and finally packed to reach all criteria required. We strongly request that you check the label (documentation/delivery note) at your factory. All data must match with your order!

(2) Our safety gears are maintenance free. Please avoid rust arising from low temperatures and/or bad storage. Lubricate all moving parts like hinges, between eccentric and steel tape, kingpin = floating arrangement.

(3)

① THE KINGPIN MUST BE REMOVABLE. SO PLEASE TAKE CARE TO ALLOW THE NECESSARY SPACE.

② GAP BETWEEN DIVERTING LINKAGE AND BORE-HOLE MUST BE ASSEMBLED BY DRILLING BORE-HOLE Ø 6,5 - 7,0 mm AND KEEPING AN ALLOWANCE OF 1 TO 2 mm.

③ STATIC BRAKE SHOE KB 55 MUST BE ADJUSTED TO THE GUIDE RAIL, LEAVE MAXIMUM 7 mm GAP / OPTIMALLY 5 mm.

(4) THE SITE ENGINEERS MUST NOTE THE FOLLOWING FOR MAINTENANCE ROUTINE:

- a) Square tube actuating shaft must be easily moveable by hand until safety gear is activated.
- b) Safety switch must be activated. When moving car in UP direction the actuating shaft must freely move back to the original position.
- c) Clean and properly maintained components are essential and guaranty a perfect function of our safety gears
- d) Lubrication of guide rails only with recommended oils.

e) COMMENT: Non lubricated guide rails are of advantage and gives clear operating.



DEBRIS, DUST ETC. WILL NOT ALLOW A FREE DYNAMIC MOVEMENT !

Edition:
26.07.2001



Manual KB 55 ↓
Installation and Maintenance

Drawing No.:
5260.800.004

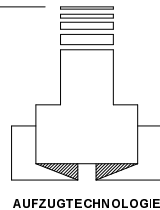

AUFZUGSTECHNOLOGIE

FRONT SIDE

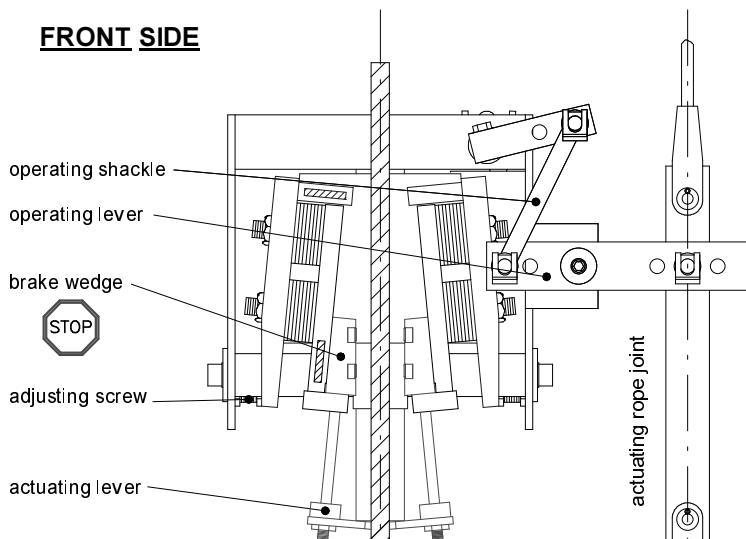

BACKSIDE

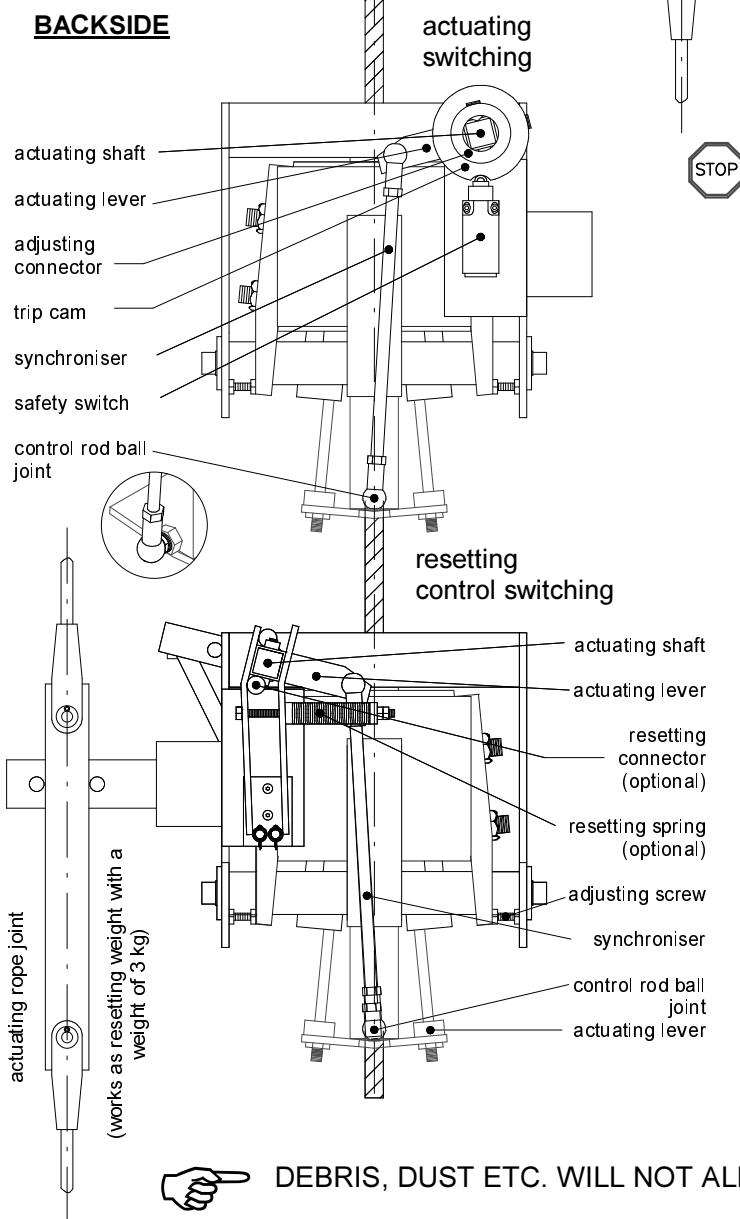

Preliminary Note

We can not accomplish the pre-positioning in our works. Experienced site engineers must carry out the adjustment on site.

(1) Preparation

- Diverting part must be fixed on both sides. The gap should be 1 - 2 mm !
- Remove the actuating lever.
- Remove all switches.
- Adjust the restoring cam at position and fix properly.
- Impose tension on restoring spring.
- Finally fix the actuating lever at correct position.

(2) Adjustment of KB 55 for synchronous operation

- The actuating lever must be become unbound from the free-wheeling fork and ball joints.
- Housing adjustment bolts must be turned into the unit.
- Push the actuating lever in UP direction, if not possible by hand use the hammer (with care !) and fix it. This is the position where the brake wedges start to act.
- Turn the housing adjustment bolts out, the gap must be 1 mm. Tighten the bolt by means of a lock nut. Please observe: The bolt head must not touch the housing.
- Turn the actuating rod and position the ball joints onto the actuating lever.
- The still fixed actuating lever the both freewheeling forks must be brought into position (no gap !) and tightened. Make always sure that the gap is correct. A certain movement from the rope is an advantage.
- Finally turn the actuating rod back to the idle position, push the actuating lever down = this is the idle position.

(3) MAKE SURE THAT ALL PARTS ARE MOVING FREE !

(4) Check with connected rope actuating lever

- The adjustment of the actuating force is the result of the pre-tension of the return spring.
- Test in ↓ direction with empty car; can cause due to the "jumping" counter weight to varying position of the actuating lever.
- Adjust and fix the switch cam.

(5) Final Inspection

- Even with empty car and low speed the marks on the guide rails must be equally. The safety gear must go automatically back into the idle position.
-

Please refer also to our brochure with photographs !

Edition:
26.07.2001



Manual KB 55 ↓
Adjustment on Site

Drawing No.:
5260.800.005



Testing the Safety Gear: ↓

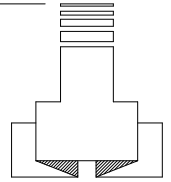

AUFZUGTECHNOLOGIE

The friction depends on several factors like hardness of the guide rail surface, roughness and the surface hardness of the brake shoes of the safety gear unit. The brake force is also vital. The brake force depends on the adjusted end point of the selected springs. The friction coefficient is the result of:

- a) Material and form of the brake shoes
- b) -> Hardness and roughness of the guide rails
-> Type and viscosity of the lubrication oil

Experienced lift engineers will before starting the installation drive check the installed car sling. The actuating, braking distance, and engaging should be checked before hand. During this test the overspeed governor will be checked as well.



WE ARE PLEASED TO HAND OVER THE SPRING LOAD CHARACTERISTICS CURVES AND ADJUST- AND RE-ADJUST INSTRUCTIONS TO LIFT ENGINEERS WILLING TO ACCEPT RESPONSIBILITY.

reading of marks



DOWN



Before handing over , a safety gear test must be performed.

- a) 1,25 x contract load, open brake on gear, do not loop safety switches of overspeed governor and safety gear
- b) contract load, open brake on gear, do not loop safety switches of overspeed governor and safety gear

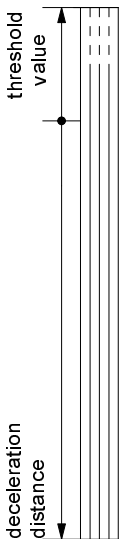

CANCEL THE BRAKE POSITION: FAST PASSING

Depending on site condition you may test the lift several times to assure that under all conditions the system is working perfect. The principle is main ropes under tension - main ropes slack. In case you can not get the car out of the safety gear a traction sheave clamp is useful. Also with the assistance of the hand winding procedure it will ease the car.

In the DOWN direction mode during a short threshold period and in the deceleration mode a massive energy conversion will take place.

$$\text{deceleration [g]: } a = \frac{v^2}{2 \cdot s \cdot 10} = \frac{[\quad]^2}{2 \cdot [\quad] \cdot 10}$$

v = deceleration start speed [m/s]; s = deceleration distance [m]; a = deceleration [g];



DEBRIS, DUST ETC. WILL NOT ALLOW A FREE DYNAMIC MOVEMENT !

Edition:
26.07.2001



Manual KB 55 / KB 55 S ↓
Check

Drawing No.:
5270.800.006

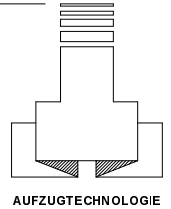

SAFETY GEAR ↓





WHY ARE YOU NOT MAKING YOUR LIFE EASIER !

Working with lifts needs a sense of responsibility and is also sometimes hard physical work. You can take a lot of the strain from your site engineers by following our suggestion based on our long experience in the field.



(a) KEEP ALWAYS AMPLE ROOM AROUND ALL CONSTRUCTION PARTS OF THE CAR SLING AND SAFETY GEAR COMPONENTS:

-  The kingpin must be easily removed.
-  Keep easy access for works on the safety gear.
-  Keep sufficient room at the car framework to check actuating gear and safety switch and each part.

(b) Make sure free and easy running:

-  At turning the actuating shaft no obstacle is to be feared.
-  At stressed resetting spring and safety switch screwed on the pulling force on the governor rope may not surpass 300 N.

(c) DO NOT USE HEAVY OVERSPEED GOVERNOR ROPE TENSION WEIGHT:

-  Our tension weight DrawingNo. 5230.260.300 is tailor made for our units.
-  Tension weight exceeding 60 kg demolishes the actuating shaft components and complicated the release of the safety gear blocks.

(d) CHECK ALL THE COMPONENTS IN ACCORDANCE TO EN 81.

(e) READ OUR INSTRUCTION MANUAL CAREFULLY.

(f) THE SAFETY GEAR ↓ IS THE SIGNIFICANT PART OF THE LIFT CONSTRUCTION. HENCE MAKE ABSOLUTELY SURE EVERY CARE IS TAKEN TO INSTALL THE COMPONENTS CORRECT.

-  Clean and properly maintained components are essential and guaranty a perfect function of our safety gears!

Edition:
26.07.2001



Safety Book - GENERAL - 1
Safety Gear - ENVIRONMENT

Drawing No.:
5230.800.016

Annex D

SAFETY GEAR ↓

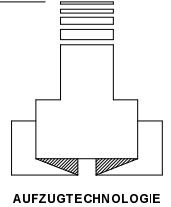

D.2 Tests and verifications

⋮

j) car safety gear (9.8):

the energy which the safety gear is capable of absorbing at the moment of engagement will have been verified in accordance with F.3. The aim of the test before putting into service is to check the correct mounting, correct setting and the soundness of the complete assembly, comprising car, safety gear, guide rails and their fixing to the building.

The test shall be made while the car is descending, with the required load uniformly distributed over the car area, with the machine running until the ropes slip or become slack, and under the following conditions:

⋮

2. progressive safety gear:

the car shall be loaded with 125 % of the rated load, and travel at rated speed or lower.

When the test is made with lower than rated speed, the manufacturer shall provide curves to illustrate the behaviour of the type tested progressive safety gear when dynamically tested with the suspensions attached.

After the test, it shall be ascertained that no deterioration, which could adversely affect the normal use of the lift has occurred. If necessary, friction components may be replaced. Visual check is considered to be sufficient.

Note:

In order to facilitate disengagement of the safety gear, it is recommended that the test be carried out opposite a door in order to be able to unload the car.

Edition:
26.07.2001



Safety Book - GENERAL - 2
Extract from European Standard prEN 81-1

Drawing No.:
5230.800.017

SAFETY GEAR ↓

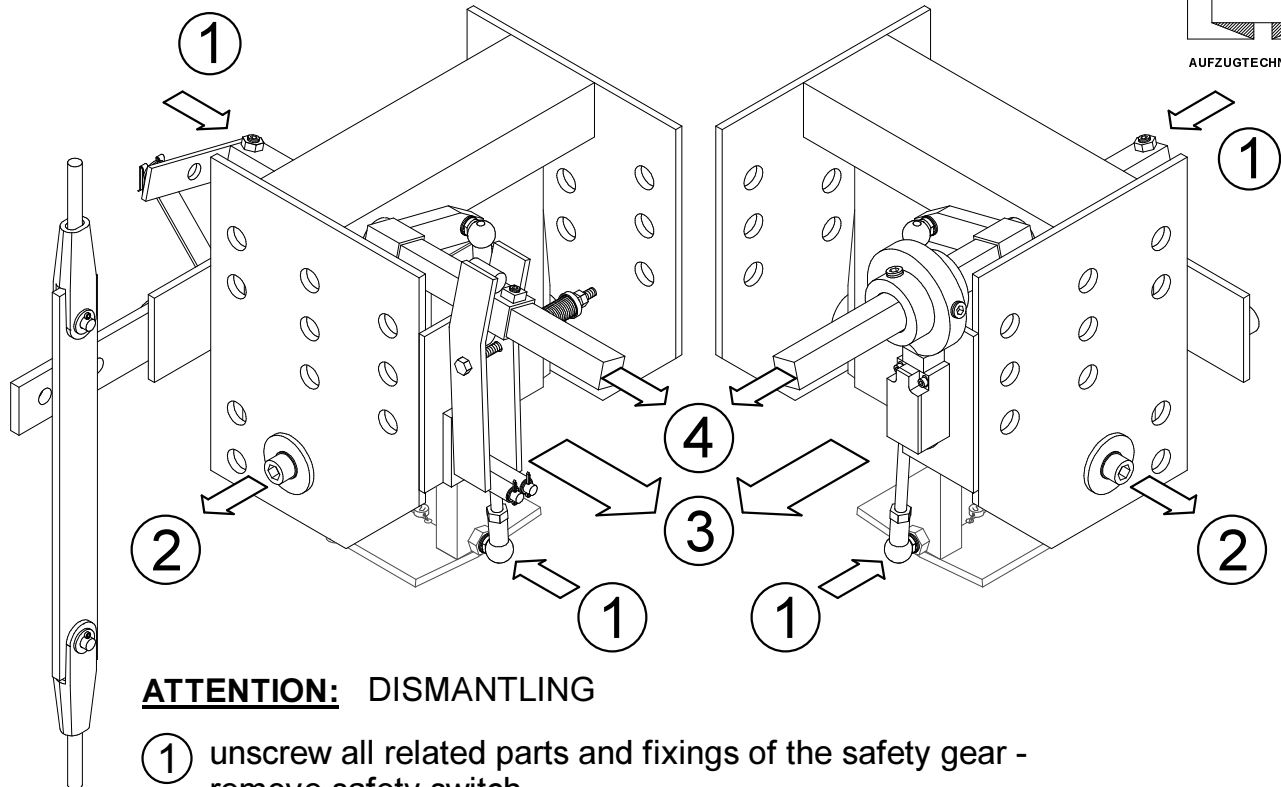
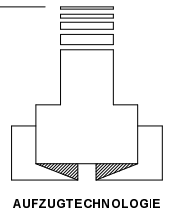

ATTENTION: DISMANTLING

- ① unscrew all related parts and fixings of the safety gear - remove safety switch
- ② unscrew the fixings and remove the kingpins
- ③ the complete safety gear unit must be removable without taking any parts of the car sling

ATTENTION: ACTUATING SHAFT

- ④ actuating shaft with axial gap of 1-2mm, movable by hand

ATTENTION: ASSEMBLING

NOly clean guide rails and brake shoe surface will give you the full performance - don't put the safety gear units in before you checked this.

- Fwe tested paint thinner "LUSIN 400"
- otherwise: Cold Cleaner
Dieseloil
Rust Preventer
- Follow the recommendations of the guide rail suppliers !

ATTENTION: TAKE CARE TO USE JUST APPROPRIATE LUBRICANTS !



DEBRIS, DUST, ETC. WILL NOT ALLOW A FREE DYNAMIC MOVEMENT !

Edition:
26.07.2001



Safety Book - CHECKLIST
Safety Gear ↓ KB 55 / KB 55 S

Drawing No.:
5260.800.007

Safety Switch - IDLE POSITION
Safety Module (↑↓)

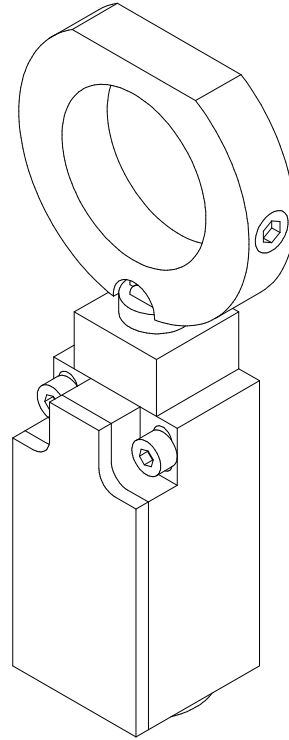
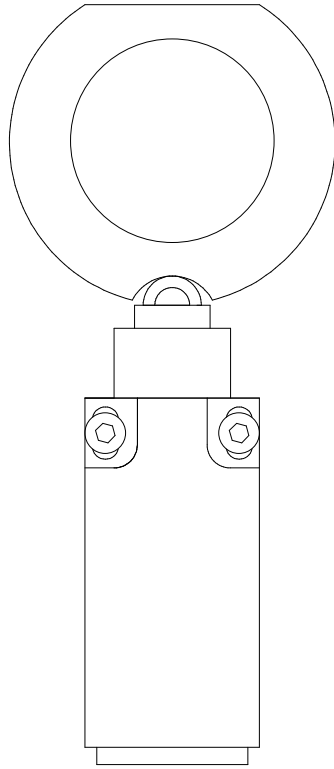

Safety Switch - IDLE POSITION
Safety Gear (↓)

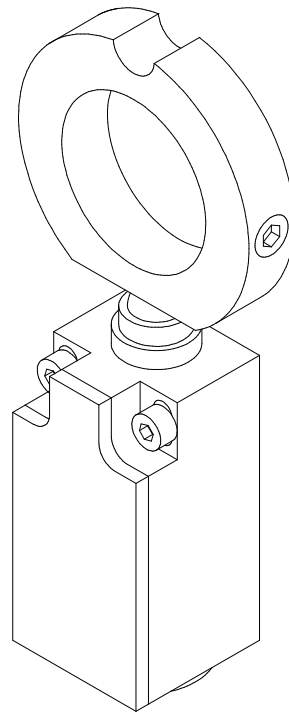
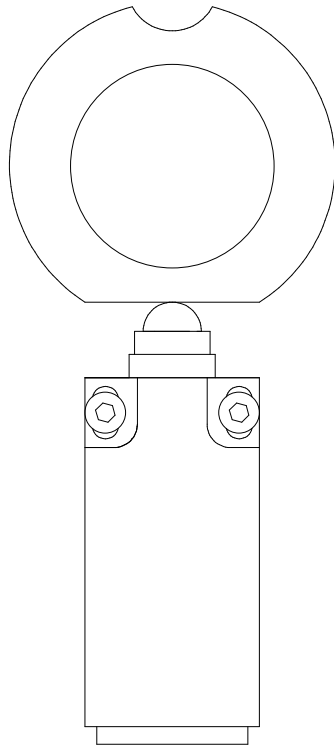

Edition:
 26.07.2001



SAFETY SWITCH in IDLE POSITION

Drawing No.:
 5230.800.018